



1477K9WHITE

**Carrinho de ferramentas E77
Premium de 26" com 9 gavetas
branco 693 mm x 510 mm x 965
mm**



DETALHES DO PRODUTO

- O sistema DAAT único assegura que apenas uma gaveta pode abrir de cada vez
- Gavetas de abertura completa com amortecedores de canto individuais com proteção de choque
- Sistema de fecho pivotante
- Rodas com sistema de travagem duplo
- Construção de caixa de parede dupla em aço sólido
- Sistema de fecho definitivo com controlo de acesso eletrónico disponível
- Sistema modular de acessórios Xpand disponível
- Revestimento de pó à prova de riscos disponível em três cores: laranja, cinzento e preto

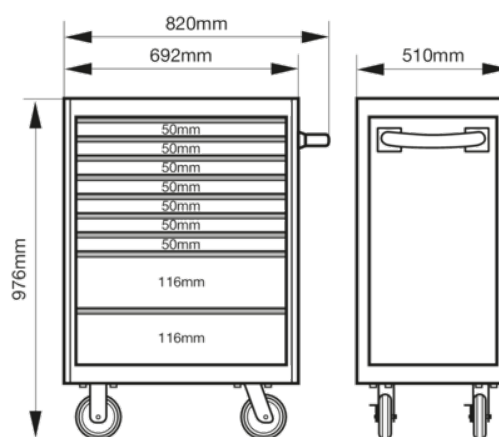

Follow the Fish!



ATRIBUTOS DO PRODUTO

Produto										RAL
1477K9WHITE	976 x 510 x 820 mm	1000 kg	9	445 mm	543 mm	45 kg	125 mm	36 mm	91 kg	9003

Follow the Fish!

