



BH13000
3T Premium Trolley Jack



PRODUCT DETAILS

- 3T trolley jack designed for lifting the widest range of standard vehicles
- 90 mm height entrance and 552 mm elevation achievable height
- Dual piston system decreases the number of necessary strokes by 50%
- Extra large foot pedal and composite curved handle for quick, safe and comfortable use
- Improved cardan stopper system prevents overturning and deformation
- Steel and PU wheels ensure both excellent durability and silent handling
- Dust cover protects the pistons and spring from being damaged
- Rubber saddle protects vehicle surfaces and prevents slipping
- Foam on the handle prevents damaging the vehicle body
- Equipped with a safety pressure valve and descent speed control system
- CE certified by Official Independent Technical Inspection Association

Follow the Fish!



Ref	h1	h2
BH1EU3000	195	250
BH11500	145	200
BH12000	145	200
BH13000	165	220
BH13000QA	170	225

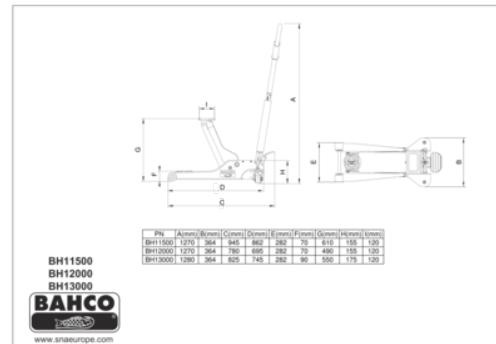
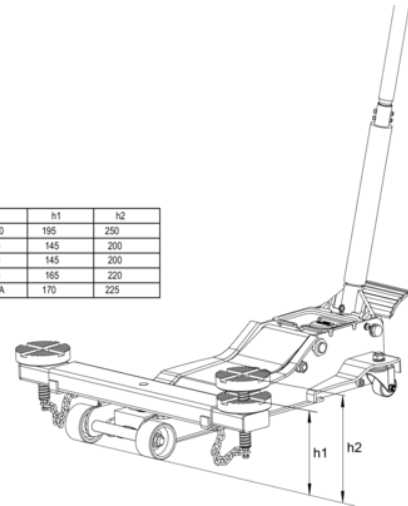

PRODUCT ATTRIBUTES

商品										
BH13000	3000 kg	90 mm	552 mm	825 mm	+/- 11	119 mm	x	X	1280 x 364 x 825 mm	48.5 kg

Follow the Fish!

