



BH6AC1-680A Engine Hoist Load Balancer



PRODUCT DETAILS

- For easily lifting and balancing of engines or suspended loads with an offset centre of gravity
- 680 kg maximum load capacity
- Balance point adjustable by foldable handle, 190 mm either side of centre
- 640 mm length for easy attachment of larger engines
- Heavy duty welded chain (Ø7.5 mm) and solid mounting plates
- Suitable accessory for our range of cranes: BH6FC1000, BH6FC2000 and BH6PC600
- CE certified by Official Independent Technical Inspection Association

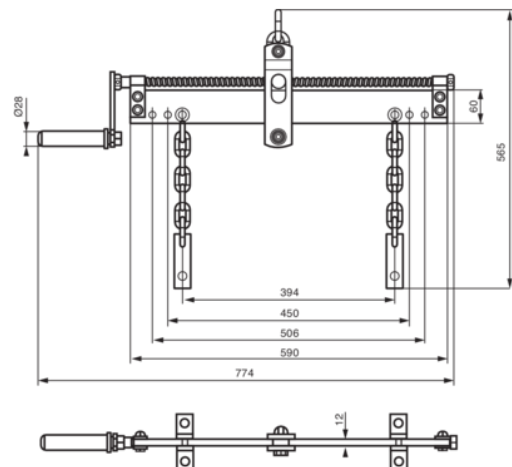

Follow the Fish!



PRODUCT ATTRIBUTES

Product	A	B			
BH6AC1-680A	774 mm	195 mm	680 kg	565 x 12 x 774 mm	7.6 kg

