



BH1A1500A **Aluminium Wagenheber 1,5 T**



PRODUKTDDETAILS

- Aluminium Wagenheber 1,5 T, zu 100 % aus Aluminium, daher besonders leicht, ideal für den mobilen Einsatz bei Autorennen und im Pannendienst
- Nur 12,8 kg Gesamtgewicht
- Geringe Unterfahrhöhe: 85 mm
- Hubhöhe: 415 mm
- Inklusive praktischer Transporttasche
- Schnelles Anheben auch unter Vollast dank Doppelkolben
- Praktisches Ablagefach zur Aufbewahrung von Werkzeug, Schrauben, Muttern usw.
- Hubstange mit Schaumstoff- und Gummimanschetten zum Schutz der Karosserie
- Aluminiumräder
- CE-zertifiziert

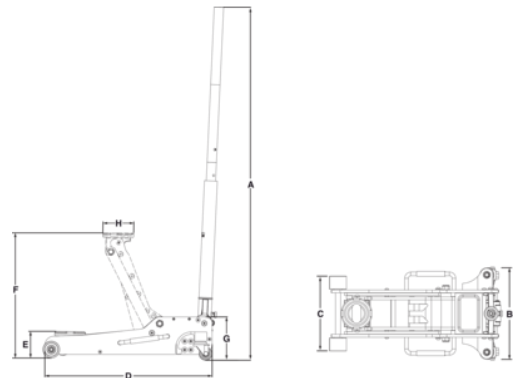









Follow the Fish!



PRODUKTEIGENSCHAFTEN

Produkt: **BH1A1500A**

	1500 kg		85 mm		415 mm
	542 mm		5		97 mm
	Yes	A	1060 mm	B	250 mm
C	218 mm	D	542 mm	E	85 mm
F	415 mm	G	130 mm	H	97 mm
	12.8 kg				

